

# Serck Audco Valves

OWNERS MANUAL FOR SUPER-H PRESSURE BALANCED PLUG VALVES



Installation,

Operation and,

In-Line Maintenance Instructions



## Serck Audco Valves

Section	Contents	Page	Section	Contents	Page
<b>1.0</b>	Introduction	3	<b>7.2</b>	Stem Packing Adjustment	13
<b>2.0</b>	General Description	3	7.2.1	Confirming a Stem Leak	13
2.1	Internal Components	4	7.2.2	Description	13
<b>3.0</b>	Product Identification	5	7.2.3	Injecting Stem Packing	13
3.1	Visual Appearance	5 & 6	7.2.4	Reloading the Stem Packing Injector	13
3.2	Nameplate Information	7	<b>7.3</b>	Adjustment of Plug Loading Screw	14
3.3	Body markings	7	7.3.1	When to Adjust the Plug Loading Screw	14
<b>4.0</b>	Receipt and Storage	8	7.3.2	Adjusting the Plug Loading Screw	14
4.1	Packaging	8	<b>7.4</b>	Rotating the Plug Through 180 degrees	15
4.2	Receipt	8	7.4.1	Rotating the Plug on Wrench Operated Super-H Valves	15
4.3	Storage	8	7.4.2	Rotating the Plug on Gear Operated Super-H Valves	15
<b>5.0</b>	Installation, Painting and Cleaning	8	<b>7.5</b>	Gear Operator Maintenance	15
5.1	Preparation for Installation	8	<b>8.0</b>	Trouble Shooting Guide	16
5.2	Installation Configuration	8	8.1	Hard to Operate	16
5.3	Lifting into Position	8	8.2	Will Not Fully Open or Close	16
5.4	Lifting Lugs	8	8.3	Leaks Across Seats	16
5.5	Making End Connections	8	8.4	Leaks at Stem	16
5.5.1	Flanged Connections	8	8.5	Leaks Through Gear Unit	16
5.5.2	Threaded Connections	8	8.6	Leaks at Cover	16
5.5.3	Welded Connections	8	8.7	Leaks Through Sealant Fitting	16
5.6	Installing Wrench Operators	9	8.8	Leaks Through Valve Body	16
5.7	Installing Gear Operators	9	8.9	Actuated Valves	16
5.8	In-Line Painting	9	<b>9.0</b>	Maintenance of Type-H Plug Valves	17
5.9	In-Line Internal Cleaning	9	9.1	Type-H Sealant Injection	17
5.10	Insulation	9	9.2	Type-H Stem Packing Adjustment	17
5.11	Commissioning Tests	9	9.3	Type-H Adjustment of Plug Loading Screw	17
<b>6.0</b>	Operation	10	9.4	Type-H Reversal	17
6.1	Principle	10	<b>10.0</b>	Super-H Valve Overhaul & Repair	18
6.2	Operating Wrench Operated Valves	10	10.1	Disposal of Worn Out Valves	18
6.3	Operating Gear Operated Valves	10	<b>11.0</b>	Recommended Spare Parts	19
<b>7.0</b>	In-Line Maintenance	11-15			
<b>7.1</b>	Injection of Valve Sealant	11			
7.1.1	Frequency of Sealants Injection	11			
7.1.2	Sealant Injection Equipment	11			
7.1.3	Valve Sealants & Lubricants	11			
7.1.4	Injecting Sealant	12			

Cover Photo: 3" Class 900 Super-H Valves in 316 stainless steel on a manifold handling crude oil, brine and carbon dioxide. An enhanced oil recovery system.

# Introduction & General Description



Serck Audco Valves

**1.0 Introduction** The information in this manual will assist you in the installation, operation and maintenance of your Serck Audco 'Super-H' plug valves. By following these instructions every valve should give reliable service for many years. The Super-H series superseded our "Type-H" series over the period 1982-84. There are numerous Type H still in service and section 9 of this manual gives instructions specific for the Type H series plug valve.

**2.0 General Description** Serck Audco Super-H valves are Pressure Balanced Taper Plug Valves. They are designed to give bubble tight shutoff on both high and low pressure applications. This is a robust, In-Line Maintainable valve with low maintenance requirements. The valve body is a rigid single piece casting or forging. The blow out proof valve stem is internally assembled and retained in the body. The separate plug is retained in the body by a bolted or threaded cover. The design incorporates provision for external adjustment of the stem packing, the plug position in the valve seats and allows for valve sealant to be injected onto the valve seats, which are the tapered surfaces of the body and plug. Please refer to our 'Super-H Pressure Balanced Plug Valves' catalogue for more details on the valve design.

The figure below shows a sectional view of a typical Super-H valve.

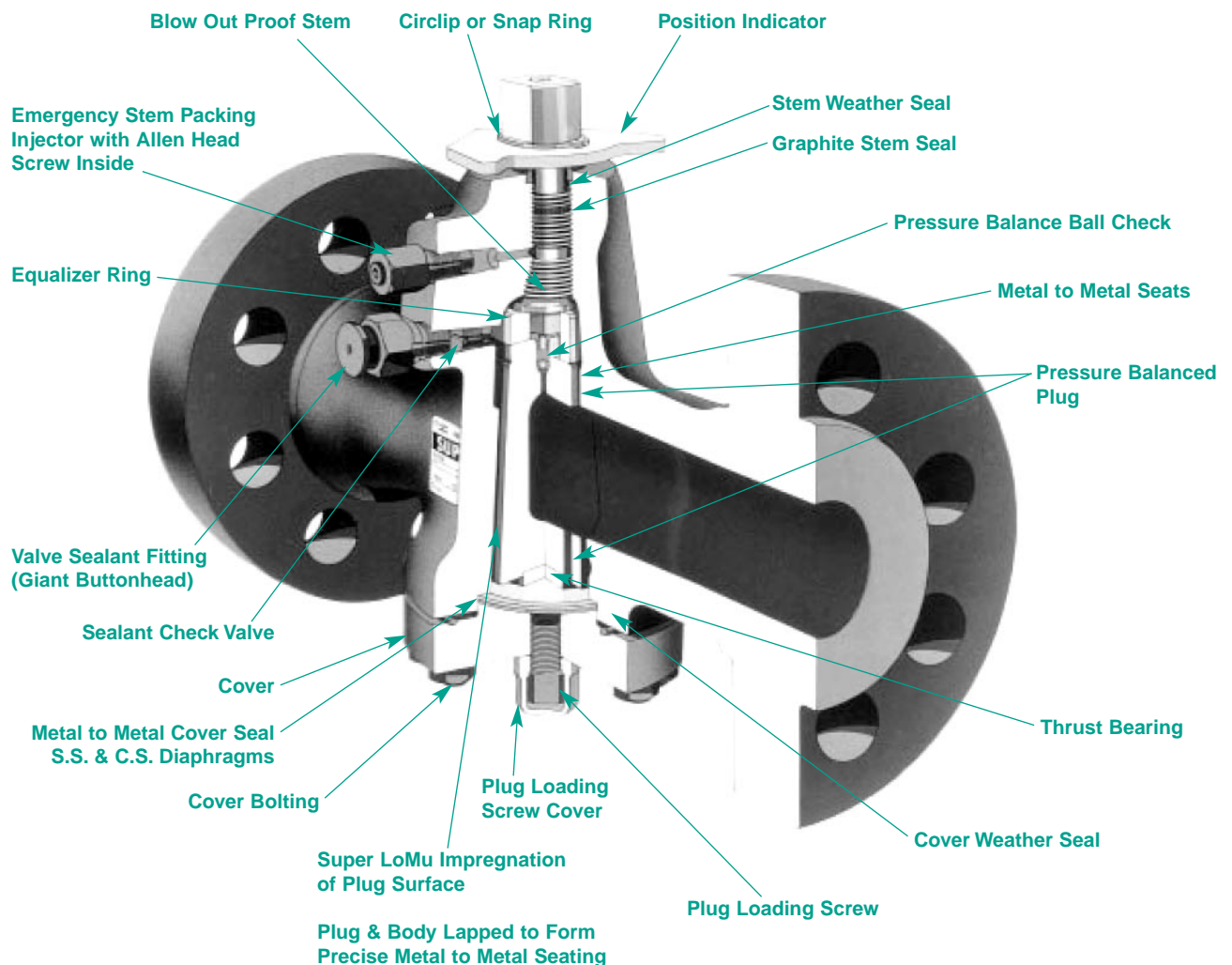



# Internal Components

## Serck Audco Valves

### 2.1 Exploded View of Typical Super-H Valve

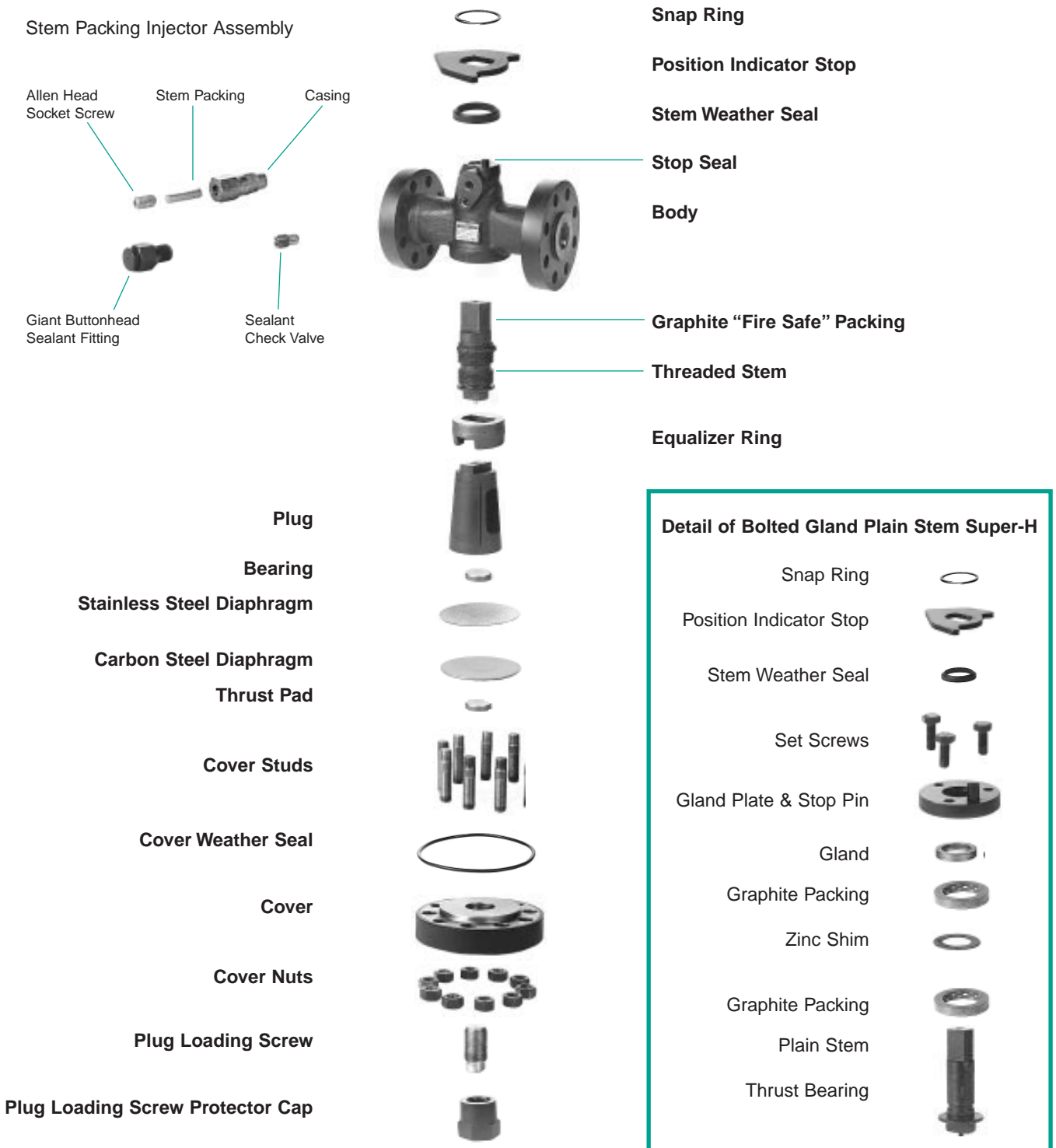



# Product Identification



Serck Audco Valves

**3.0 Product Identification** Before attempting to work on any valve, it is important that you first identify the valve as far as possible by Type, Manufacturer, Size, Pressure Class and Figure Number.

**3.1 Visual Appearance** The Super-H range covers valve sizes 1/2"-24" and ANSI pressure classes 150 to 2500. Consequently different parts of the range can have visual differences. The following series of photographs illustrates most of the variants and identifies the location of the three important maintenance features, stem packing unit, sealant fitting and plug adjusting screw.

**a. 1/2"-1" ANSI Class 150-2500**

- Threaded Stem.
- No gland on this design.
- Side feed stem pack unit.
- Side feed sealant fitting.
- Threaded Cover.
- Plug adjusting screw.
- Normally wrench operated.

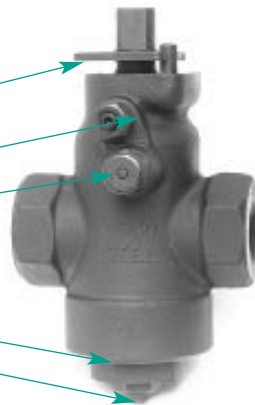

**b. 1.1/2"-4" ANSI Class 150-600**

- Plain Stem design.
- Bolted non-adjustable gland.
- Side feed stem packing unit.
- Side feed sealant fitting.
- Bolted Cover.
- Plug adjusting screw cover.
- Normally wrench operated.

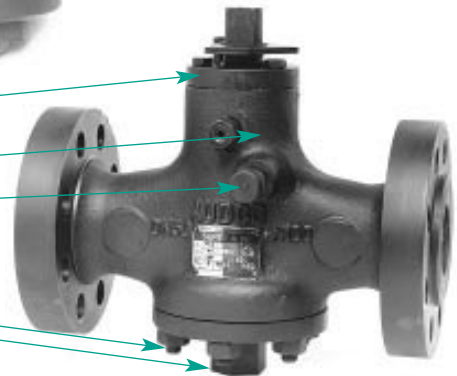

**c. 1.1/2"-4" ANSI Class 900-1500**

- Threaded Stem.
- No gland on this design.
- Side feed stem packing unit.
- Side feed sealant fitting.
- Bolted Cover.
- Plug adjusting screw cover.
- Normally wrench operated.

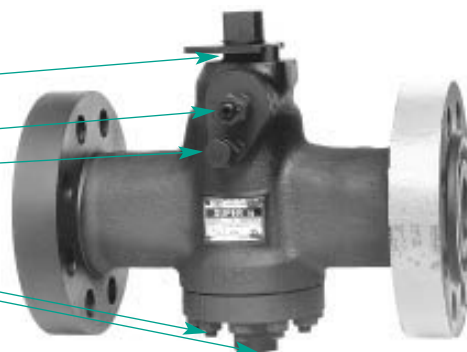

**d. 1.1/2"-3" ANSI Class 2500**

- Threaded Stem.
- No gland on this design.
- Side feed stem packing unit.
- Side feed sealant fitting.
- Threaded cover with 3 packing fittings.
- Plug adjusting screw.
- Normally wrench operated.

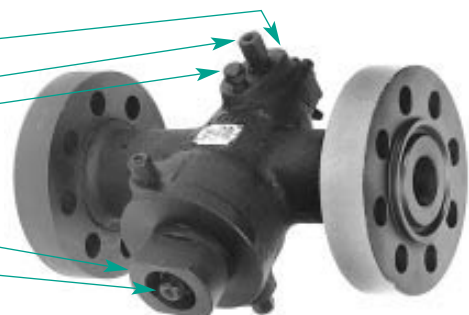



# Product Identification

## Serck Audco Valves

### 3.1 Visual Appearance, Continued

#### e. 6"-24" ANSI Class 150-900

(Early Design 83-91)

Threaded Stem.

No gland on this design.

Side feed stem packing unit.

Sealant fitting on top of stem.

Bolted Cover.

Plug adjusting screw cover.

Normally gear operated.

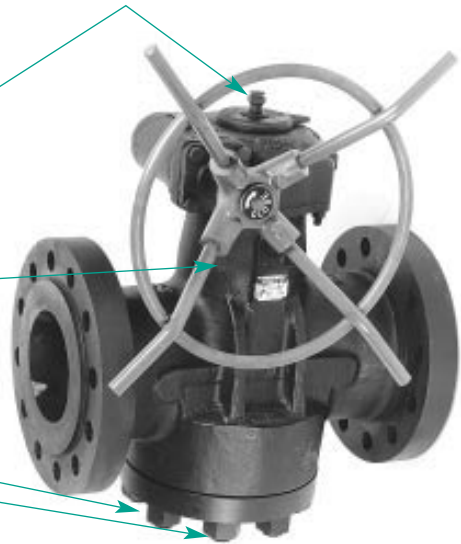

#### f. 6"-24" ANSI Class 150-900

(Later design 91 onwards)

4'-16' ANSI Class 1500

Threaded Stem.

No gland on this design.

Side feed stem packing unit.

Side feed sealant fitting.

Bolted Cover.

Plug adjusting screw cover.

Normally gear operated.

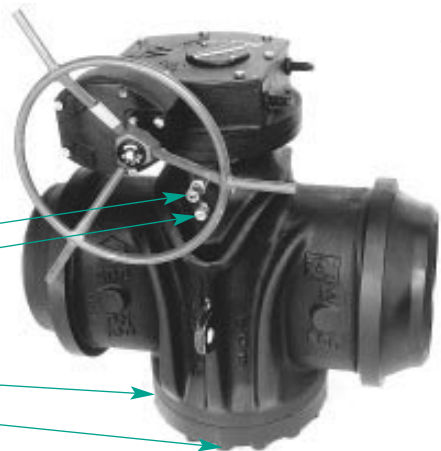

#### g. 3"-8" ANSI Class 2500

Threaded Stem.

No gland on this design.

Side feed stem packing unit.

Side feed sealant fitting.

Threaded cover with 3 packing fittings.

Plug adjusting screw.

Normally gear operated.

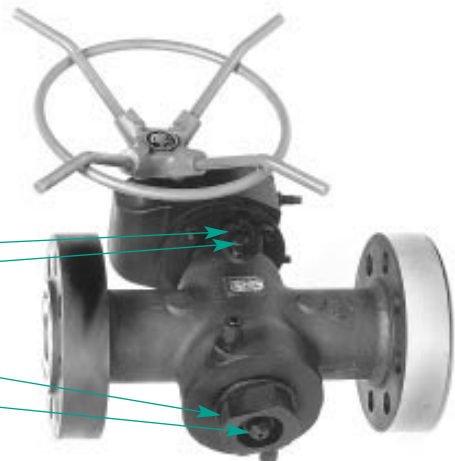

# Nameplate & Body Markings



Serck Audco Valves

**3.2 Nameplate Information** All Super-H plug valves are fitted with nameplates at the Serck Audco Valves factory. Two different sized nameplates are used as shown here.



**1/2"-1" Super-H Nameplate.**



**1.1/2"-24" Super-H Nameplate.**

Nameplate information is abbreviated. The table below explains the terms and abbreviations used.

**No.** Unique valve serial number which allows Serck Audco to trace the date of manufacture of the valve.  
**Example** CDJF0001.

**FIG** Figure number, preceded by the valve size. Example 2"HRW633CC.  
If an 'S' followed by a 4 digit number is shown then the valve is a special. Consult SAV. for identification.  
Figure numbers are explained below.

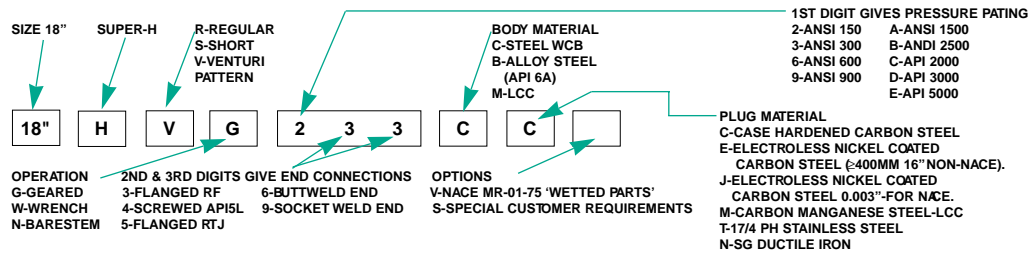

**BODY** BODY material. Normally an abbreviation of the ASTM material specification eg.  
WCB = ASTM A216 grade WCB  
WCC = ASTM A216 grade WCC  
LCB = ASTM A352 grade LCB  
LCC = ASTM A352 grade LCC  
CF8M = 316 Stainless Steel (18/10/3)

**PLUG** PLUG material, abbreviated.  
SH.CS = Surface Hardened Carbon Steel  
CS.EN - Electroless Nickel Plated Steel  
17/4 = Stainless Steel grade 17/4 PH

**STEM** STEM material, abbreviated  
CS = Carbon Steel  
17/4 = Stainless Steel grade 17/4 PH.  
CR13 = 13% Chrome alloy steel.  
NiCu = Monel K500.

**API** Gives API 6D/ANSI pressure class.  
Example 600 = ANSI class 600

**MOP** Maximum Operating Pressure in psi.  
Example 1480 - ANSI class 600.

**3.3 Body Markings** Super-H valves have several cast characters on the body. These include:

Our Name.	'AUDCO'	and trademark	
Valve Size in inches	eg '12'	Metric size	eg DN300
ANSI/API pressure rating	eg 300	Metric pressure class	eg PN20
Body material ASTM abb	eg WCB	Foundry mark	e.g. WF - Wilsons Foundry

There are also characters stamped on the body including:  
Melt Number eg 1234 (often stamped next to the foundry mark)  
This can be traced back to the original material certificate provided by the casting supplier.  
Valves subject to non-destructive testing will have additional characters which reference the NDT tests.

Serck Audco serial number eg CDJF0001 (should match nameplate)  
Valve covers are also stamped with characters including the material grade and traceable melt number.  
Cover bolting is normally stamped with material grade e.g. B7 = ASTM A193 grade B7.



# Storage & Installation

## Serck Audco Valves

### 4.0 Receipt and Storage

**4.1 Packaging** Serck Audco Valves ships Super-H valves either in skid mounted enclosed wooden crates or banded to wooden skids. We encourage our distributors to ship them in a similar fashion so that the material can easily be handled by forklift trucks. All valves are shipped with the plug in the fully open position. Wooden or plastic end protectors are normally fitted.

**4.2 Receipt** Upon receipt all valves should be carefully inspected for loss or damage during shipment and any claims should be promptly submitted to the carrier as well as notifying the shipper.

**4.3 Storage** If the valves are not going to be installed immediately, we recommend that they be stored undercover in a clean, dry place. Flange, weld end and thread protectors should be left in place.

### 5.0 Installation

**5.1 Preparation for Installation** Move the valves as close as possible to the installation site before removing packaging and protectors. After removing packaging, clean end connections to remove any unwanted paint or rust inhibitor. Ensure that the valve is fully open. Inspect the internal bore of the valve. If there is excess sealant visible around the plug ports, this should be scraped out. If the valve has been in storage for over 12 months we recommend that additional valve sealant be injected prior to operation. See section 7.1.

**5.2 Installation Configuration** Audco Super-H plug valves have bi-directional sealing capabilities. Therefore, except on valves with two different end connections (e.g. weld end x flange) or where there are space constrictions that dictate handwheel position, the valves can be installed in any position, horizontal, vertical or at any angle in-between.

**5.3 Lifting into Position** Valves should always be lifted using suitable mechanical lifting equipment operated by trained personnel. Chains, slings and other lifting equipment should be regularly inspected. Do not lift valve using the sealant fittings, gear unit, handwheel or wrench. Chains or slings should be fixed around the valve body.

**5.4 Lifting Lugs** Most 6" and larger Super-H valves are fitted with two or more lifting lugs on either side of the body. These lugs are positioned so that the valve can be safety lifted with the valve stem or gear box uppermost. It is important that all the lugs provided are used so that the valve is balanced.

**5.5 Making End Connections** Super-H valves are manufactured in accordance with API 6D and ANSI B16.34 standards. The end connections are machined in accordance with the requirements of these specifications, unless otherwise specified by the customer. The standard finished ends comply with:

Flanged Raised Face	ANSI B16.5, serrated spiral finish 250-500 microinch (AARH).
Flanged Ring Joint	ANSI B16.5 table 5.
Butt Weld Ends	ANSI B16.25 fig. 1.a. weld ends are bored to match the customer specified pipe schedule.
Threaded Ends	ANSI B1.20.1, NPT female dry seal taper pipe thread.
Socket Weld Ends	ANSI B16.11

**5.5.1 Flanged Connections** Selection of gaskets and bolting is the customers responsibility but as a minimum they should meet the requirements of ANSI B1 6.5. Flanges should be pulled together evenly by tightening opposite pairs of bolts.

**5.5.2 Threaded Connections** As Super-H valves have steel bodies, pipe wrenches can safely be used to grip the valve body adjacent to the connection, while tightening it. The threads are suitable for forming dry seals so the use of thread sealants is at the customers discretion.

**5.5.3 Welding Connections** All welding should be performed by qualified welders using approved procedures. Due to its thick sections, the valve acts as a good heat sink during welding. Provided good industry accepted practices (such as ASME IX) are used, the heat from the welding will not affect the valve internals. There are no soft seats to be affected, but if the valve is subject to excess heat from bad welding, the valve sealant could start to decompose and the stem packing could also be affected. Local post weld heat treatment (PWHT) of the heat affected zone is safe but we do not recommend that the entire valve be subjected to PWHT. Degradation of the valve sealant and stem packing can occur if the valve is heated to over 750 degrees f (400 deg. c) for a substantial period of time. Distortion of the internal components is possible at higher temperatures.



# Installation & Commissioning



Serck Audco Valves

**5.6 Installing Wrench Operators** Wrench Operators for Super-H valves can be fitted either with the wrench head central or at one end of the wrench. To reposition it, unscrew the retaining screw, move the head top the desired position, insert the screw and retighten. The wrench head is a "Double D" style so that the wrench can only be fitted parallel with the plug port, ie. when the valve is closed, the wrench is at right angles to the piping, indicating closed as is the normal convention. When the wrench is fitted to the valve and it is going to be left there, the retaining screw should be screwed into the hole in the top of the valve stem.

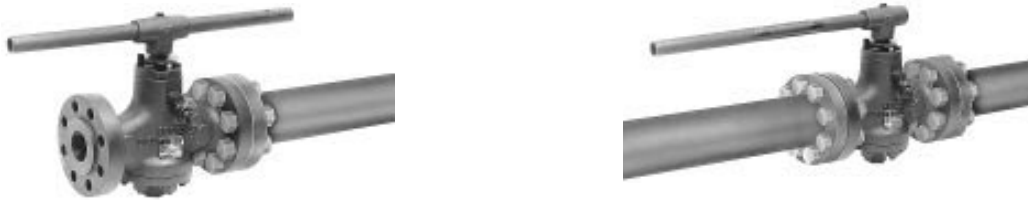

**5.7 Installing Gear Operators** Gear Operators are normally factory installed and the internal stops have been preset and should not require adjusting. Handwheels are attached to the gear box input shaft either by a taper pin or a key. When installing the handwheel, ensure that the close direction indicator is visible on the end of the input shaft and that the retaining bolt is tightened down. After the handwheel has been installed and providing the valve is not under pressure, the valve should be operated from fully open to fully closed and back again to ensure that the operator does not interfere with any other adjacent equipment or piping.

**5.8 In-Line Painting** Super-H valves are suitable for in-line painting. The following areas should be masked with rubberized masking materials or caulk, before shot blasting:

- |                             |  |
|-----------------------------|--|
| Top of stem and gland area. | - Body-Cover joint (unless fitted with rubber weather seal). |
| Stem packing injector.      | - Gear box fittings, input shaft and stop adjusters.         |
| Sealant fitting.            | - Top works of bare stem valves that are to be fitted with   |
| Exposed end connections.    | actuators or extensions.                                     |

We also recommend that the above areas be protected with a thick rust inhibitor or grease rather than be painted. By following this recommendation, the user will ensure that no shot gets into valve, that wrench and handwheel operators will fit easily and the maintenance fittings are not damaged.

**5.9 In-Line Internal Cleaning** It is common practice for valve users to internally clean piping systems including the valves, particularly during start up, to remove dirt, scale, weld splatter, welding rods etc. This cleaning is usually done by flushing with water, steam, air, carbon dioxide or solvents. Due to the metal to metal seats, there are no soft seats to be damaged in Super-H valves. It is possible to damage the metal seats if the valve is left partially opened and flushed at high velocities. The valve should be fully opened or fully closed during cleaning operations. The valve sealant can be damaged by certain cleaning media. Water and inert gases such as carbon dioxide and nitrogen are unlikely to affect the sealant. If solvents or steam cleaning is used, then we recommend that after the cleaning operation is completed, all valves be reinjected with Audco sealant suitable for the intended service. Please consult Serck Audco Valves for sealant recommendations.

**5.10 Insulation** Super-H valves can be insulated to retain process heat or protect from low ambient temperatures. We recommend that the insulation allows easy access for maintenance to the sealant and stem packing fittings, as well as the valve operator.

**5.11 Commissioning Tests** Serck Audco Valves recognizes that many customers will subject valves to extended duration commissioning tests which far exceed the factory test durations. All valves are factory tested in accordance with industry standards (API 6D, API 6A or ANSI B16.34) or as specified by the customer. Serck Audco Valves does not accept responsibility for valves that fail on field tests at higher pressures than the applicable factory test, unless the higher field test pressure has been previously agreed to in writing between Serck Audco Valves and the customer. We recommend that the gear operator stops be checked during the commissioning tests.

If water used for testing, then after the testing is completed, it is beneficial to dry out the valve internals by flushing the system with dry nitrogen or air.



## Serck Audco Valves

### 6.0 OPERATION

**6.1 Principle** Super-H valves are quarter turn valves, i.e. they have a 90 degree rotation of the plug in operating from fully open to fully closed. This operation is always clockwise to close, when viewed from above the valve stem. Maximum operating torque occurs during approximately the first 15 degrees of plug rotation when opening the valve from the fully closed position. Past 15 degrees the down line seat is broken and run torque drops to approximately 40% of the break torque, on a well maintained valve.

**6.2 Operating Wrench Operated Valves** Wrench operated valves have an arrow shaped position indicator fitted over the stem. The arrow points in the direction that the plug port is aligned. When the arrow points across the line of the pipe, the valve is closed. The indicator should not be removed as it also functions as the open and close stop by coming into contact with the stop pin adjacent to the stem.

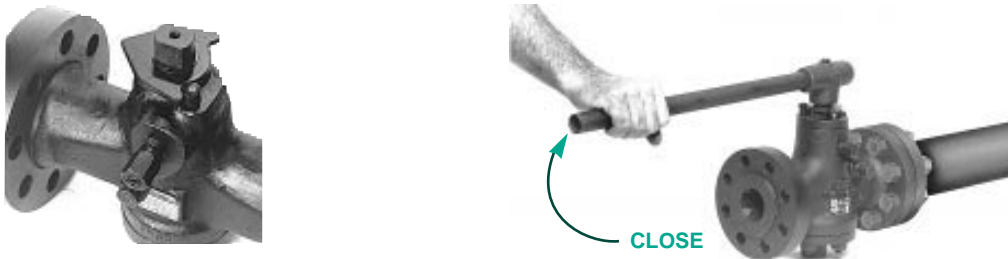

Wrench operated valves should be operated with the correct size of Audco wrench. If this is not readily available an adjustable wrench (crescent wrench) can be used but care should be taken not damage the flats on the stem. Audco wrenches are sized so that the force required to operate the valve should be a maximum of 100 pounds applied at the end of the wrench. Do not force valves that will not operate readily. Refer to the trouble shooting guide for advice first.

**DO NOT USE PIPE WRENCHES TO OPERATE SUPER-H PLUG VALVES-**They will damage the flats on the stem.

**6.2 Operating Gear Operated Valves** All worm gear operators used by Serck Audco have visible arrow type position indicators on the top of the gear housing. The arrow is fixed either directly to the valve stem or onto the gear quadrant so that a direct indication of position is achieved. 'OPEN' & 'SHUT' positions are cast on the top of the gear housing. The position indicator arrow points to these at the fully opened or closed positions.

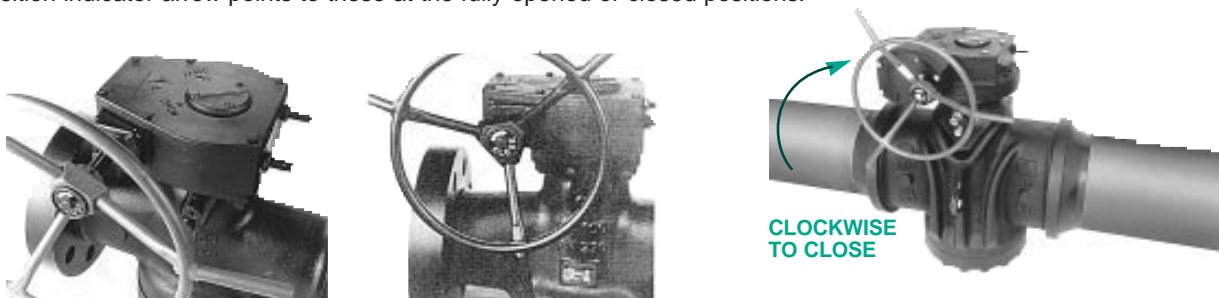

Gear operators should be fitted with the correct size of handwheel as supplied by Serck Audco Valves. Gear operators are always clockwise to close and this is indicated by the arrow on the close indicator in the center of the handwheel. The number of turns required to open or close the valve varies with the gear operator fitted. See our Accessories leaflet on gears for more information or consult Serck Audco Valves.

**6.3 NEVER STAND DOWNSTREAM OF A VALVE THAT IS BEING OPENED TO ATMOSPHERE.**

**6.2** Valves that are installed in locations where unauthorized personnel can interfere with them should normally have the wrench or handwheel removed, be locked with suitable locking devices or be chained through the handwheel to prevent operation.

# In-Line Maintenance, Sealant Injection



Serck Audco Valves

**7.0 In-Line Maintenance** There are four maintenance operations that can be carried out on Audco Super-H valves while in-line and on service. With these operations, except in cases where the plug becomes heavily eroded, corroded or damaged, Super-H valves can be fully maintained in-line for many years of trouble free service.

The four operations are:

- injection of valve sealant (required occasionally).
- injection of stem packing (emergency feature).
- adjustment of the plug loading screw (unlikely to ever be required).
- rotating the plug through 180 degrees (unlikely to ever be required).

**7.1 Injection of Valve Sealant** The reason for injecting valve sealant onto the valve seats of Audco Super-H plug valves is to maintain the bubble tight shutoff capabilities and to ensure smooth operation of the valve.

EQUIPMENT NEEDED: High Pressure Sealant Injection Gun with pressure gauge.  
Plug Valve Sealant (suitable for service).

**7.1.1 Frequency of Sealant Injection** This is dependent on the service conditions and how often the valve is operated. We recommend the following, (For further advice contact Serck Audco Valves.)

Service Conditions	Frequency of Sealant Injections
A. Infrequent operation, valve either fully opened or fully closed. Non abrasive gases or liquids.	Every 50 operations, minimum once per year.
B. Infrequent operation, valve either fully opened or fully closed. Abrasive gases or liquids.	Every 25 operations, minimum of 2 times a year.
C. Throttling services and abrasive slurries.	Every 10 operations, minimum of 4 times per year.

**7.1.2 Sealant Injection Equipment** All Super-H valves are fitted with "Giant Buttonhead" sealant fittings, unless the customer specifies special fittings such as sub-sea. To inject sealant into Super-H valves, a high pressure sealant gun with a giant buttonhead coupler is required. The gun should also have a pressure gauge reading to at least 10,000 psi. There are three basic types available and Serck Audco can supply all three (see Sealants & Injection Equipment section of our catalogue). These are:

- Manual primed with screw feed, inexpensive guns for occasional use.
- Manual with hydraulic feed, recommended for servicing small groups of valves.
- Pneumatic, uses bulk lubricant in 5 quart or larger cans, recommended for large valve installations such as manifolds, gas processing plants, compressor stations, and refineries.

NOTE: Do not attempt to use low pressure lubricant guns (e.g. those used to grease wheel bearings) on Audco plug valves.

**7.1.3 Valve Sealants & Lubricants** Only sealants recommended for use in TAPER plug valves should be used. Serck Audco can supply sealants suitable for most services and there are other manufacturers who also make good sealants. If you already have a particular valve sealant in use at a facility, we will advise on the suitability of it for its use in Super-H plug valves, on a particular service.

**We strongly recommend against the following types of sealant**

- Sealant supplied by cylindrical/parallel plug valve manufacturers. These are of much higher viscosity than taper Plug valves require and will substantially increase the valve torque if used.
- Commercially available lubricating grease such as bearing grease. These greases do not have the chemical resistance, lubricating and sealing properties required by taper plug valves.
- Sealants with high levels of bentonite clay filler (such as Rockwell/Nordstrom number 555). With this type of sealant the base oil evaporates (particularly on dry gas services) leaving behind a hard layer of clay filler which can make the valve hard to operate and even seize it up.



# Sealant Injection

## Serck Audco Valves

**7.1.4 Injecting Sealant** The following instructions should be used in conjunction with the sealant gun manufacturers instructions. Sealant can be injected with the valve in line and on pressure.

**7.1.4.1 Position** If possible the valve should be either fully opened or fully closed. This ensures that all four sealant grooves on the plug are connected to the sealant supply. If the valve is partially open, injection is less effective as only two of the grooves are connected to the supply.

**7.1.4.2 Sealant Fitting** Identify and clean the giant buttonhead fitting on the valve. In particular scrape off any paint build-up away from the small hole in the end of the fitting.

**7.1.4.3 Fill the Gun** Ensure that the gun is filled and primed with a suitable plug valve sealant. Follow the gun manufacturers instructions to fill the gun.

**7.1.4.4 Attach the Gun** Slide the buttonhead coupler on the end of the gun hose, over the valve's giant buttonhead fitting, ensuring that the lip of the coupler fits into the groove in the fitting. If the gun has an isolating valve on the coupler or else where, open this valve.

**7.1.4.5 Start Pumping** Inject sealant either by pumping the handle on a manual gun or connecting the air supply to the pneumatic gun. The pressure gauge needs to be monitored during the sealant injection process. For sealant to flow onto the valve seats, enough sealant at sufficient pressure has first to be injected to overcome the line pressure, to fill any cavities in the sealant chamber and grooves and to overcome the resistance to flow through the valve sealant system.

Sealant is flowing onto the seats when the pressure gauge on the gun is significantly higher than the line pressure and falls slowly. On low pressure Super-H or valves off pressure, a minimum of 2,000 PSI sealant pressure is needed to ensure proper injection of sealant onto the seats.

With a valve that is regularly injected with sealant, the sealant pressure will quickly build up. A valve that has not been well maintained could require a significant amount of sealant to be injected before pressure builds up and sealant flows onto the seats. See section 9. "Trouble Shooting Guide" for potential injection problems.



Manual-hydraulic sealant gun being used to lubricate 2" Super-H valve.



Pneumatic sealant gun (5 quart size) being used to lubricate 6" early design Super-H valve with the sealant fitting on top of the stem.

**7.1.4.6 Disconnect** After sufficient sealant has been injected, relieve the internal pressure in the gun and disconnect it from the giant buttonhead fitting. **CAUTION:** The lubricant gun should not be connected or disconnected while it has internal pressure.

**7.1.4.7 Operate the Valve** It is desirable but not essential, to operate the valve either partially or fully, after injecting sealant as this helps to spread the sealant over the entire seating surfaces.

# Stem Packing Adjustment



Serck Audco Valves

**7.2 Stem Packing Adjustment** All Super-H plug valves are fitted with an emergency stem packing fitting. In the unlikely event of a Super-H valve developing a stem leak, this fitting can be used to inject stem packing into the stem area and reseal the valve stem. This can safely be done with the valve under pressure.

On threaded stem Super-H valves the injected stem packing is the primary stem seal. On the "plain stem" design with bolted top gland, it is purely an emergency feature to back up the main stem packings.

**CAUTION:** Never attempt to replace the stem packing in bolted gland Super-H valves while under pressure. Consult S.A.V. for information of replacing these packings.

**EQUIPMENT NEEDED:** Allen key wrench (to fit stem packing injector)  
Audco Stem Sealing Compound for Super-H Valves.

**7.2.1 Confirming a Stem Leak** If a Super-H valve is suspected of leaking at the stem, this should first be confirmed by one of several methods:

- \* On wrench operated valves, a stem leak on a liquid service will be visible as liquid flowing out around where the stem protrudes from the body.
- \* On gas services, applying a detergent solution around the stem area will produce soap bubbles if the stem is leaking. A bad leak might even be heard as a hissing noise from the stem area.
- \* On gear operated valves the area where the stem protrudes from the body is hidden by the gear operator. A stem leak would have to be confirmed by observing or applying detergent solution around the fittings on the gear and the gear box to mounting plate joint area, underneath the gear.
- \* Some portable electronic hydrocarbon detectors are sensitive enough to detect stem leaks by placing the probe adjacent to the stem.

**7.2.2 Description** The stem packing injector fitting consists of an outer hexagonal shaped casing, that is screwed into the valve body. Inside it is a check valve and stem packing is forced through it with an allen socket screw that threads into the end of the casing. Stem packing injectors on Super-H plug valves are preloaded at the factory with sufficient Audco Stem Sealing Compound to reseal small leaks.

**7.2.3 Injecting Stem Packing** To inject the stem sealing compound already in the fitting, into the valve stem area, insert an allen head wrench into the allen head socket screw, in the end of the stem packing injector and rotate it clockwise until it becomes hard to turn. Normally only 1-3 turns will be possible. A maximum torque of 10 foot pounds onto the allen head wrench is all that is required to sufficiently inject the stem packing.

Operating the valve during the injection of stem sealing compound can assist in resealing the valve stem.



**Adjusting the stem packing on a 2" class 1500 Super-H**

**7.2.4 Reloading the Stem Packing Injector** If the socket screw bottoms out inside of the stem packing injector and the stem is still leaking, more stem packing needs to be loaded into the stem packing injector. This is done by backing out the socket screw, putting in a new piece of Audco stem sealing compound into the fitting and screwing the socket screw back in.

**CAUTION:** Never unscrew the stem packing injector fitting out of the valve body while the valve is under pressure.





# Adjustment of Plug Loading Screw

## Serck Audco Valves

**7.3 Adjustment of Plug Loading Screw** All Super-H plug valves have a plug loading screw which is preset at the factory to position the tapered plug in optimum contact with the tapered body, i.e. the valve will seal off bubble tight and be readily operated. Most users of Super-H plug valves will never need to adjust this fitting but occasionally it can be of benefit to adjust the plug into or out of the body seat.

**EQUIPMENT NEEDED:** Adjustable crescent wrench.  
Hammer & steel punch (to loosen cap over plug adjustment screw).

**7.3.1 When to Adjust the Plug Loading Screw** If a Super-H plug valve leaks across the seats even after injection of sufficient sealant onto the valve seats and it is very easy to operate, then the plug is probably out of adjustment (not in close enough contact with the body seat) and needs to be adjusted into the tapered body seat.

**NOTE:** Damaged metal seats can also produce these symptoms.

If a Super-H plug valve is very hard to operate, even after injection of sufficient sealant, then the plug could be pushed too far into the tapered body seat and needs adjusting out a little.

**NOTE:** Solids from clay based lubricants (555 type) or from the line media (slurries, etc.) can also make the valve hard to turn.

**7.3.2 Adjusting the Plug Loading Screw** This operation can be carried out with the valve on pressure.

**7.3.2.1 Expose the Adjusting Screw** First identify the lock nut or cap that protects the plug loading screw. It is always located in the center of the valve cover. Remove the lock nut or protector cap by unscrewing it (counter-clockwise viewed from below the valve). On valves with cast protector caps there is a notch on the edge into which a steel punch can be inserted and tapped to loosen the cap.

**7.3.2.2 Adjusting into the Tapered Seats** To adjust the plug into the body seat, use an adjustable crescent wrench to tighten the plug loading screw until it becomes significantly harder to turn. It should take no more than one turn to tighten the plug loading screw, unless the plug loading screw has already been slackened off. Once the loading screw feels tight enough, back it off by 1/8th of a turn.

**CAUTION:** Do not over tighten the plug loading screw as this will jam the plug into the body seat.



Adjusting the plug loading screw on a 2" Super-H using an adjustable crescent wrench.

**7.3.2.3 Adjusting out of the Tapered Seats** To adjust a seized or hard to turn plug out of the body taper, slacken off the plug loading screw by 1/4 turn then inject sealant into the valve and this should ease the plug out sufficiently to make it operate smoothly.

**CAUTION:** Do not remove the plug loading screw from the valve cover.

**7.3.2.4** After adjusting the plug loading screw, refit the lock nut or protector cap but do not over tighten it.

# Plug Reversal & Gear Units



Serck Audco Valves

**7.4 Rotating Plug Through 180 Degrees** Most Super-H plug valves are used in applications where the flow is always in one direction. As Super-H are primarily downstream seating, it follows that the down stream seat takes the brunt of the wear and tear from normal usage. Typically the downstream face of the plug erodes first and causes leakage. There can be instances where the downstream plug seat is eroded while the upstream plug seat is still in good condition, In such cases, by rotating the plug through 180 degrees, the good condition plug seat becomes the downstream seat and leakage will be stopped or substantially reduced, so extending the life of the valve. This procedure should not be undertaken with product flowing through the valve.

**7.4.1 Rotating the Plug on Wrench Operated Super-H Valves** The "V" shaped position indicator plate attached to the stem, stops the valve from being rotated more than 90 degrees. To rotate through 180 degrees, first slide the snapping and position indicator plate off of the valve stem and rotate the plug one half turn using the correct Audco wrench. Refit the indicator plate and snap-ring. Retest the valve seats as applicable.

**7.4.2 Rotating the Plug on Gear Operated Super-H Valves** This is a complicated procedure and should not be lightly undertaken. First fully open the valve using the gear. Then unbolt and remove the gear from the valve, noting how it was positioned. Operate the gear back through 90 degrees and then fit it back on the valve with the stem and gear key-ways aligned. Operate the valve 90 degrees using the gear then remove the gear as before and operate it back through 90 degrees. Refit the gear aligning the key ways and bolt on the gear. The plug and gear have now been rotated through 180 degrees. Retest the valve seats as appropriate,

**7.5 Gear Operator Maintenance** Gear operated Super-H valves are fitted with enclosed, water tight worm gear operators. Both single and double reduction units are used. Gear boxes are manufactured by quality suppliers such as Mastergear.

These gears are designed to function without maintenance for many years. All gears are lubricated with a heavy bearing grease when assembled and should not require subsequent lubrication. Customers can at their option add additional grease or lubricating oil to the gear box. Mastergear units can only be accessed by removing the top cover or via a gear stop hole in the casing,

If the input shaft of the gear operator gets bent or broken, we recommend that the entire gear operator be replaced as the internal bearings have also probably been damaged.



# Trouble Shooting

## Serck Audco Valves

### 8.0 Trouble Shooting Guide for Super-H Plug Valves Probable causes listed in descending likelihood order.

Trouble	Probable cause	Remedy (see section)
<b>8.1 Hard to Operate</b>	A. Lack of sealant B. Low temperature C. Dried out sealant  D. Damaged gear unit E. Plug overloaded into seat	A. Inject sealant (7.1) B. Inject low temperature sealant and/or insulate valve C. Flush valve with valve flush. Follow manufacturers instructions. Consult SAV for recommended sealant D. Consult SAV F. Reset plug (7.3.2.3)
<b>8.2 Will not fully open or close</b>	A. Improper setting of gear unit stops B. Debris in the line	A. Reset stops for proper operation. B. Clean the line
<b>8.3 Leaks across seats</b>	A. Lack of sealant B. Incorrect sealant C. Plug set incorrectly D. Damaged seats	A. Inject sealant (7.1) B. Consult SAV with service details C. Adjust plug loading screw (7.3.2.2) D. Rotate plug through 180 degrees (7.4) or consult SAV
<b>8.4 Leaks at stem</b>	A. Lack of sealant	A. Inject stem packing (7.2)
<b>8.5 Leaks at stem gear unit.</b>	A. Lack of sealant	A. Inject stem packing (7.2)
<b>8.6 Leaks at cover</b>	A. Cover bolting loose -If this does not reseal cover then suspect: B. Damaged diaphragm seal	A. Tighten cover bolts B. Remove from service & replace diaphragms
<b>8.7 Leaks through sealant fitting</b>	A. Ball check not seated B. Loose sealant check valve C. Damaged check valve	A. Inject sealant to clean & reseal check valve B. Remove from pressure & tighten check valve C. Remove from pressure & replace check valve
<b>8.8 Leaks through valve body</b>	A. Casting defect, internal corrosion or erosion	A. Remove from line & consult SAV

NOTE: Injecting sealant into a valve that is leaking through the sealant fitting is normally only a temporary fix, not a cure.

### 8.9 Actuated Valves Resolving operation problems on Super-H valves fitted with pneumatic, electric, hydraulic or gas/hydraulic actuators should be undertaken using the above recommendations in conjunction with the operator manufacturers instructions.

# Type-H Valves



Serck Audco Valves

- 9.0 Maintenance of Type-H Valves** Before the Super-H valve was introduced in 1982/83, Serck Audco Valves manufactured for 40+ years its predecessor, the "Type-H" plug valve. Due to the durability of Audco plug valves there are still thousands of Type-H valves in service. The maintenance requirements of Type-H valves are similar to Super-H and are summarized below.
- 9.1 Type-H Sealant Injection** Follow Super-H instructions (section 7.1). Due to the lack of pressure balancing in Type-H valves they require more frequent sealant injection than Super-H, to keep them operating smoothly. As a guide, inject sealant into them at least twice as often as section 7.1.1 advises.
- 9.2 Type-H Stem Packing Adjustment** All Type-H valves had threaded stems with an injected stem sealing compound as the primary stem seal. Stems can be resealed by tightening the stem packing injector and injecting Super-H stem sealing compound, sections 7.2.2 to 7.2.4. Do not over pack Type-H valves stems.
- Caution** The original stem packing in Type-H valves contained asbestos and various lubricant materials. Normal asbestos handling precautions should be taken in dismantling Type-H valves. The Super-H valve stem sealing compound does not contain asbestos.
- 9.3 Type-H Adjustment of Plug Loading Screw** The plug loading screw on Type-H valves can be adjusted in the same manner as Super-H valves, sections 7.3.
- 9.4 Type-H Plug Reversal** The plugs in Type-H valves can be rotated in the same manner as for Super-H valves, section 7.4.



Wrench operated Type-H plug valve



# Overhaul & Repair

## Serck Audco Valves

**10.0 Super-H Valve Overhaul and Repair** If by following the in-line maintenance instructions in section 7 and the Trouble Shooting Guide, section 8, you are unable to get Super-H valve to operate and seal correctly, then please contact Serck Audco Valves or our local representation for further assistance.

**10.1 Disposal of Worn-Out Valves** It is in the common interest of all manufacturers of new valves and their customers to ensure that worn-out valves are disposed of so that unscrupulous peoples do not obtain them. There are people who will attempt to pass off worn-out valves as new, surplus, reconditioned or even another brand. These people have no concern for the operative and equipment that would be put at risk from worn-out valves being put back into use. Typically these criminals have minimal assets and insurance to cover any financial claims resulting from the failure of a worn-out valve that they supplied. The end user and original valve manufacturer often end up bearing the cost.

We strongly recommend that end users dispose of worn-out plug valves by:

- A. Dismantling them and
- B. Cutting up the body and plug.

It is also beneficial to sell as scrap part of the valve to one scrap dealer and the rest to another.



# Recommended Spare Parts



Serck Audco Valves

**11.0** Serck Audco Valve recommends the following spare parts be purchased and stocked by the end user.

Customer:

Customers Ref:

Project:

Location:

S.A.V. Ref:

Range of Valves Supplied:

Service:

Duration of Recommendation: Commissioning and \_\_\_\_\_ years of operation.

## 1. Sealant

Type:                      Size

Quantity:                Each:                      Total

## 2. Sealant Injection Guns

Model:

Quantity:                Each:                      Total

## 3. Stem Packing

Type:                      Size:

Quantity:                Each:                      Total

## 4. Giant Buttonhead Sealant Fittings

Type:                      Size:

Quantity:                Each:                      Total

## 5. Stem Packing Fittings

Type:                      Size:

Quantity:                Each:                      Total

Total Recommended Spare Parts \_\_\_\_\_

These parts may be ordered from:

Recommendation By:

Date:



# Serck Audco Valves

---

Catalogues on the range of plug valves available from Serck Audco Valves include:

- "SUPER-H" Pressure Balanced Plug Valves
- Standard Type Steel Plug Valves
- Cast Iron Plug Valves
- Multiport & Steam Jacketed Plug Valves
- Accessories
- Sealants & Injections Equipment
- Operation & Maintenance
- Company Brochure

Extensive technical information & references are available upon request.

## **Serck Audco Valves**

Burrell Road, Haywards Heath, West Sussex RH16 1TL  
T: +44 (0)1444 314560 F: +44 (0)1444 314561  
Website: [www.flowserve.com](http://www.flowserve.com)



Flow Control Division